

## Internal structure and parts list

● BHE-01CS to 06CS

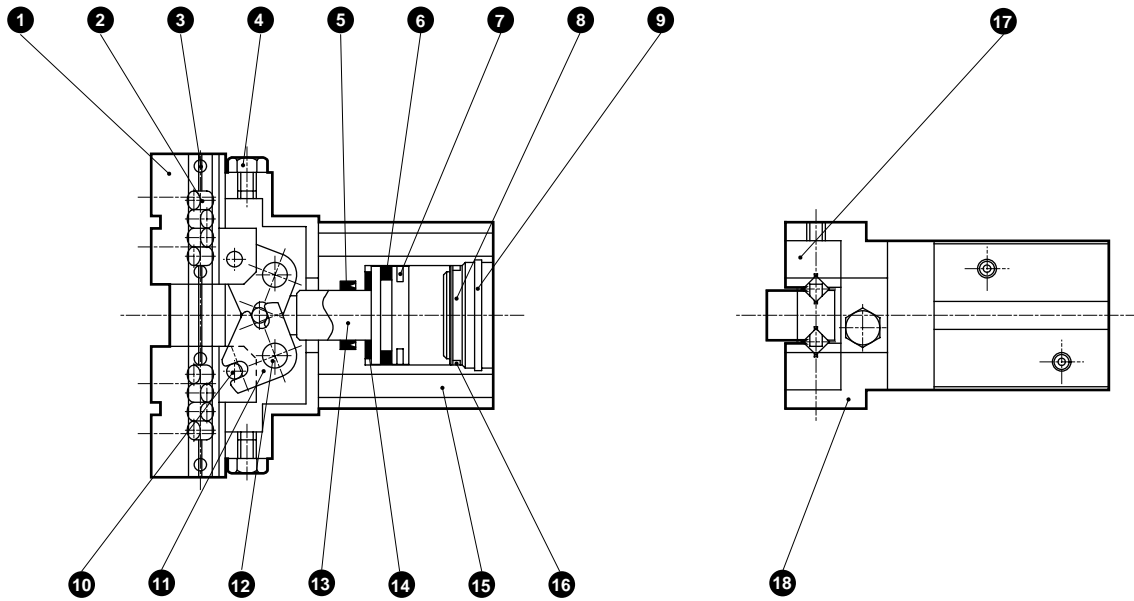

No.	Parts name	Material	Remarks	No.	Parts name	Material	Remarks
1	Master key	Stainless steel		10	Operation axis	High carbon chrome bearing steel	
2	Cross roller	High carbon chrome bearing steel		11	Arm	Stainless steel	
3	Spring pin	Stainless steel		12	Fulcrum axis	High carbon chrome bearing steel	
4	Plug	Brass		13	Piston	Stainless steel	
5	Rod packing seal	Nitrile rubber		14	Cushion	Urethane rubber	
6	Piston packing seal	Nitrile rubber		15	Cylinder	Aluminum alloy	
7	Magnet			16	Cylinder gasket	Nitrile rubber	
8	Cylinder guard	Resin		17	Bearing guide	Stainless steel	
9	Snap ring	Stainless steel		18	Body	Aluminum alloy	

## Option internal structure drawing

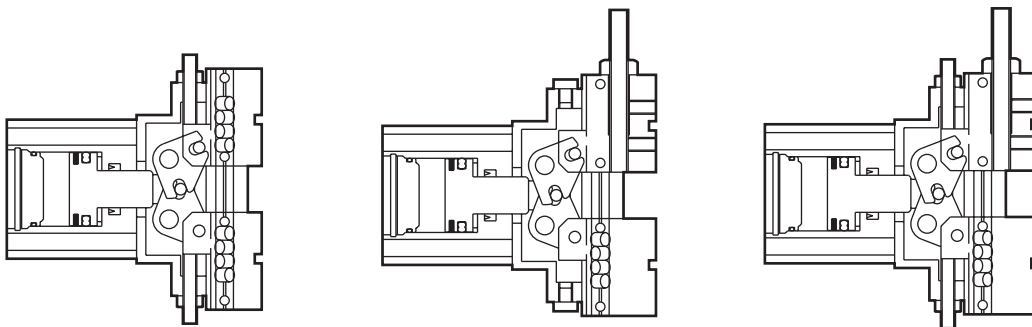

Open angle adjustment mechanism  
(Option: D)

Close angle adjustment mechanism  
(Option: E)

Open and close angle adjustment mechanism  
(Option: DE)